

EDITION / VERSİYON
10/2010

SLIDING
SÜRME

SYSTEM 38C
SİSTEM 38C

Profiler

Profiles

Profiles / profiler

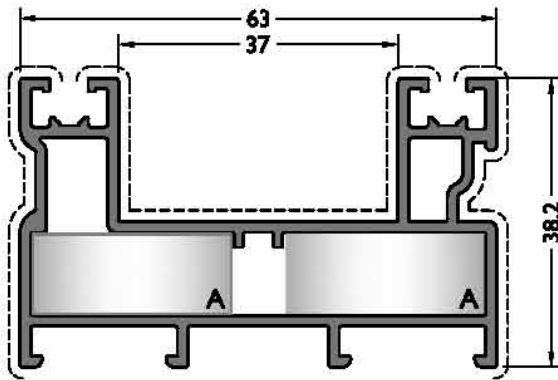

CODE

38C-101-00

THEORETICAL WEIGHT kg/m

1.090

EXTRUDED CORNER JOINT

A **CC-101-26.3**



DIE - CAST CORNER JOINT

LC-1127

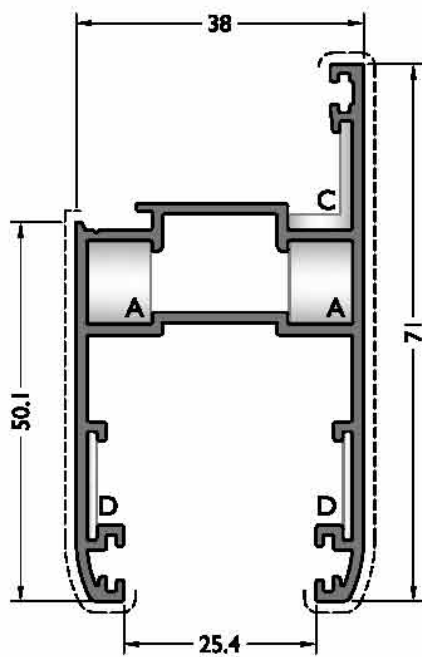

CODE

38C-201-00

THEORETICAL WEIGHT kg/m

0.953

EXTRUDED CORNER JOINT

A **CC-101-08.10**



C **EM38-21**



D **MO 20.1**

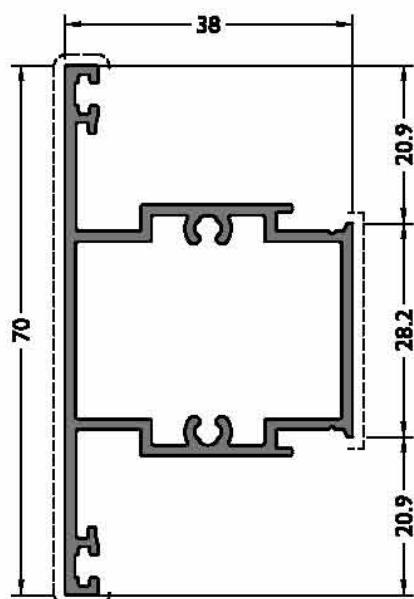

CODE

38C-302-00

THEORETICAL WEIGHT kg/m

0.834

Profiles / profiler

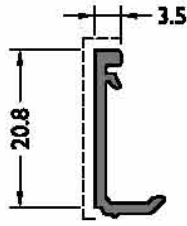

CODE
38T-801-00

THEORETICAL
WEIGHT kg/m
0.133

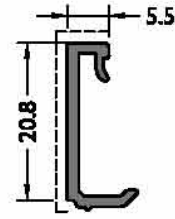

CODE
38T-802-00

THEORETICAL
WEIGHT kg/m
0.141

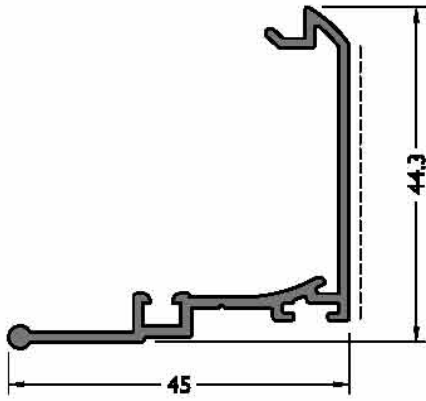

CODE
38T-502-00

THEORETICAL
WEIGHT kg/m
0.427

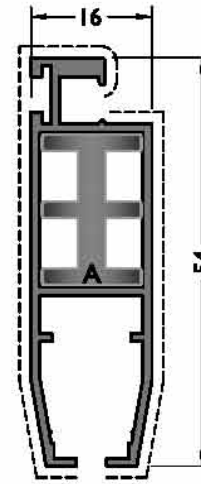

CODE
1621

THEORETICAL
WEIGHT kg/m
0.499

CORNER JOINT

A **MS 13**

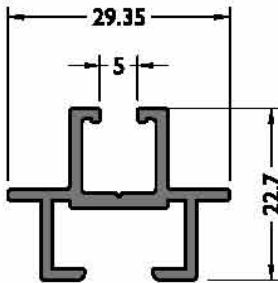

CODE
38T-503-00

THEORETICAL
WEIGHT kg/m
0.372

Görünen Yüzey Yoktur.

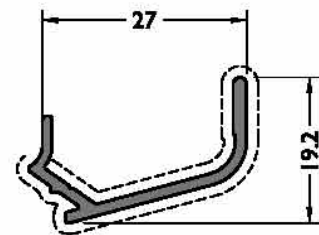

CODE
YENI

THEORETICAL
WEIGHT kg/m
0.211

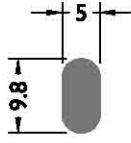

Görünen Yüzey Yoktur.

CODE

13 - 134 - 050R

THEORETICAL
WEIGHT kg/m

0.118

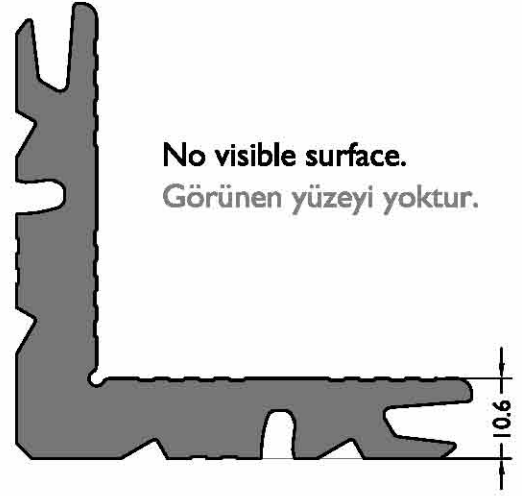

No visible surface.
Görünen yüzeyi yoktur.

CODE

09-101-00

THEORETICAL
WEIGHT kg/m

2.570

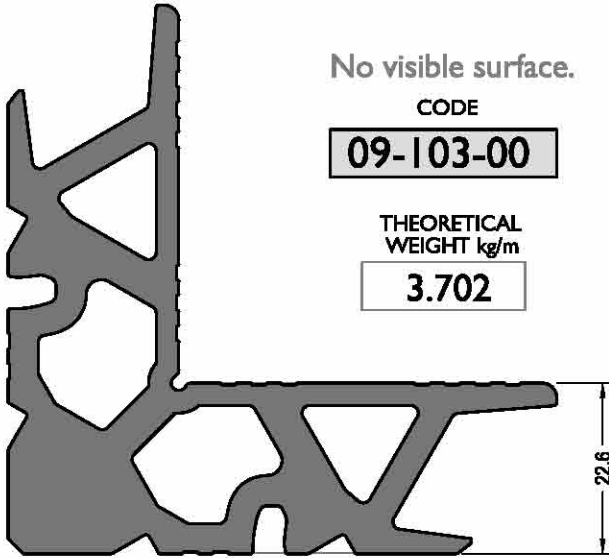

No visible surface.

CODE

09-103-00

THEORETICAL
WEIGHT kg/m

3.702

Detaylar

Details

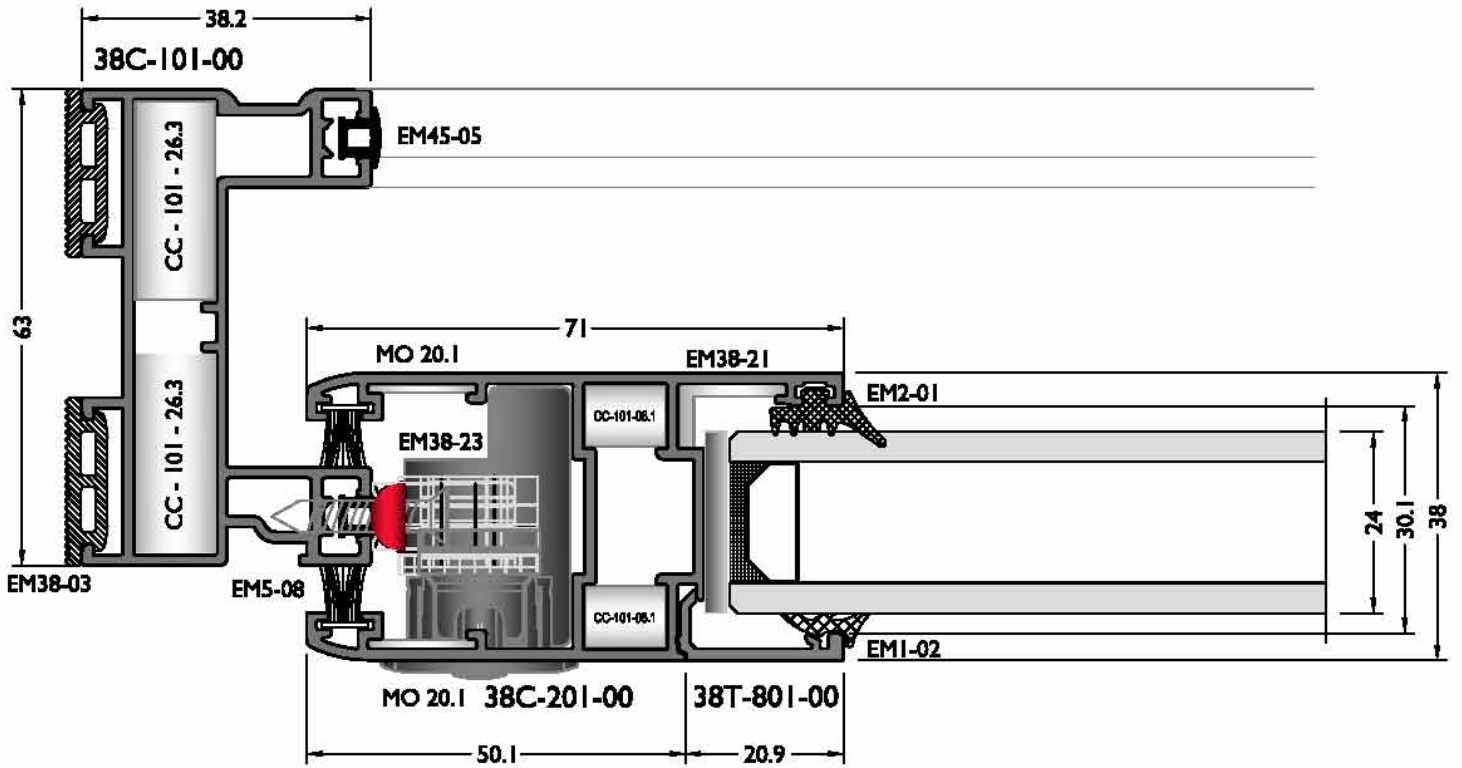
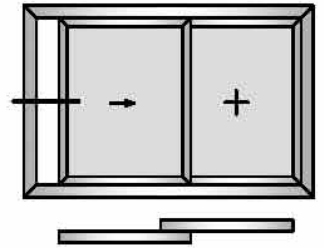
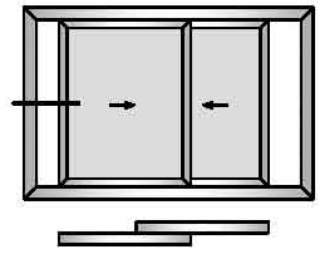

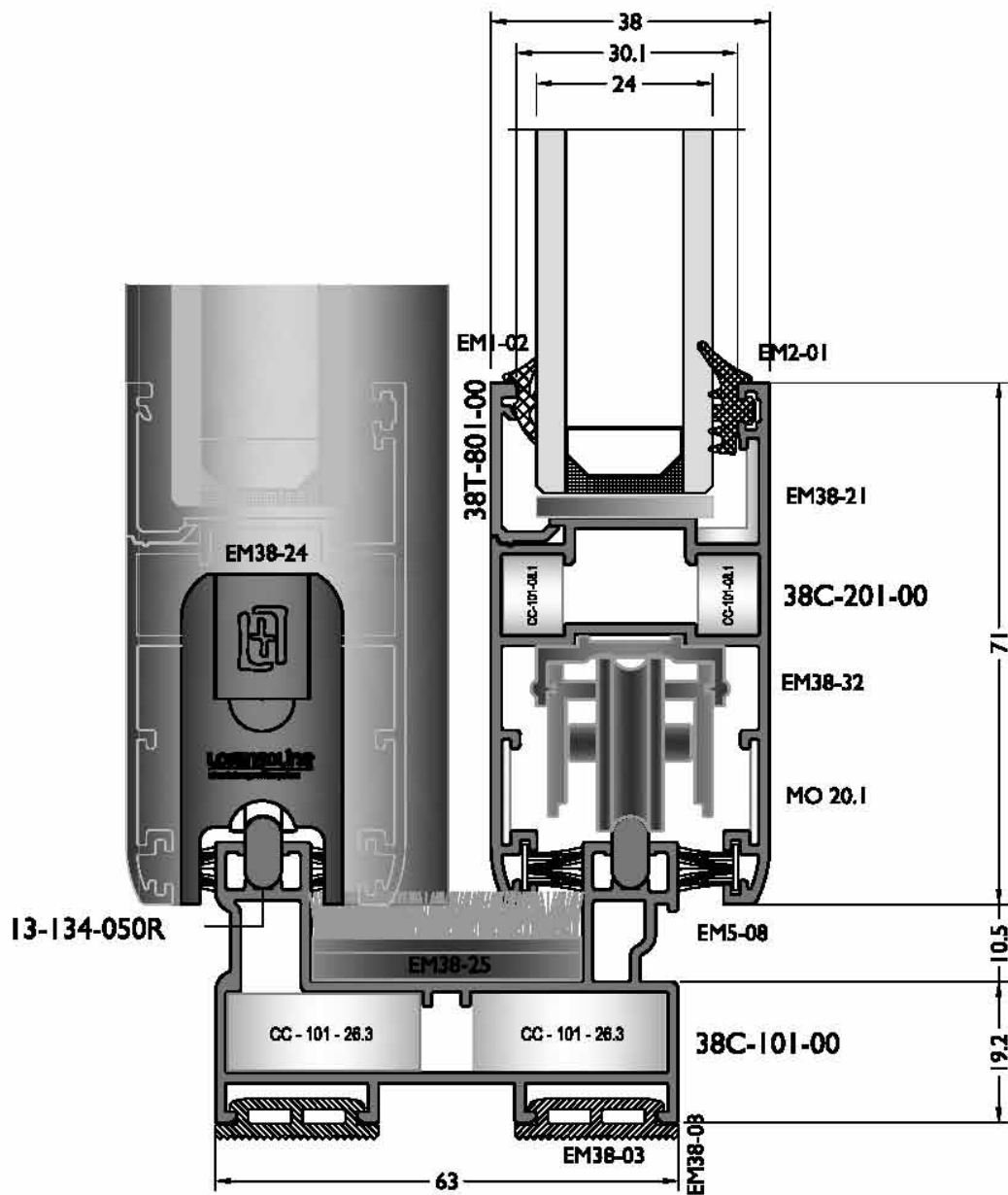
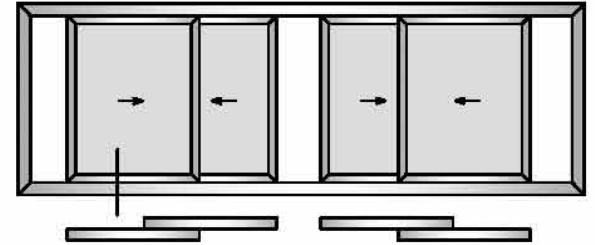
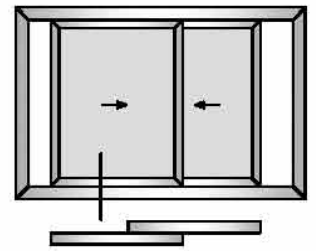

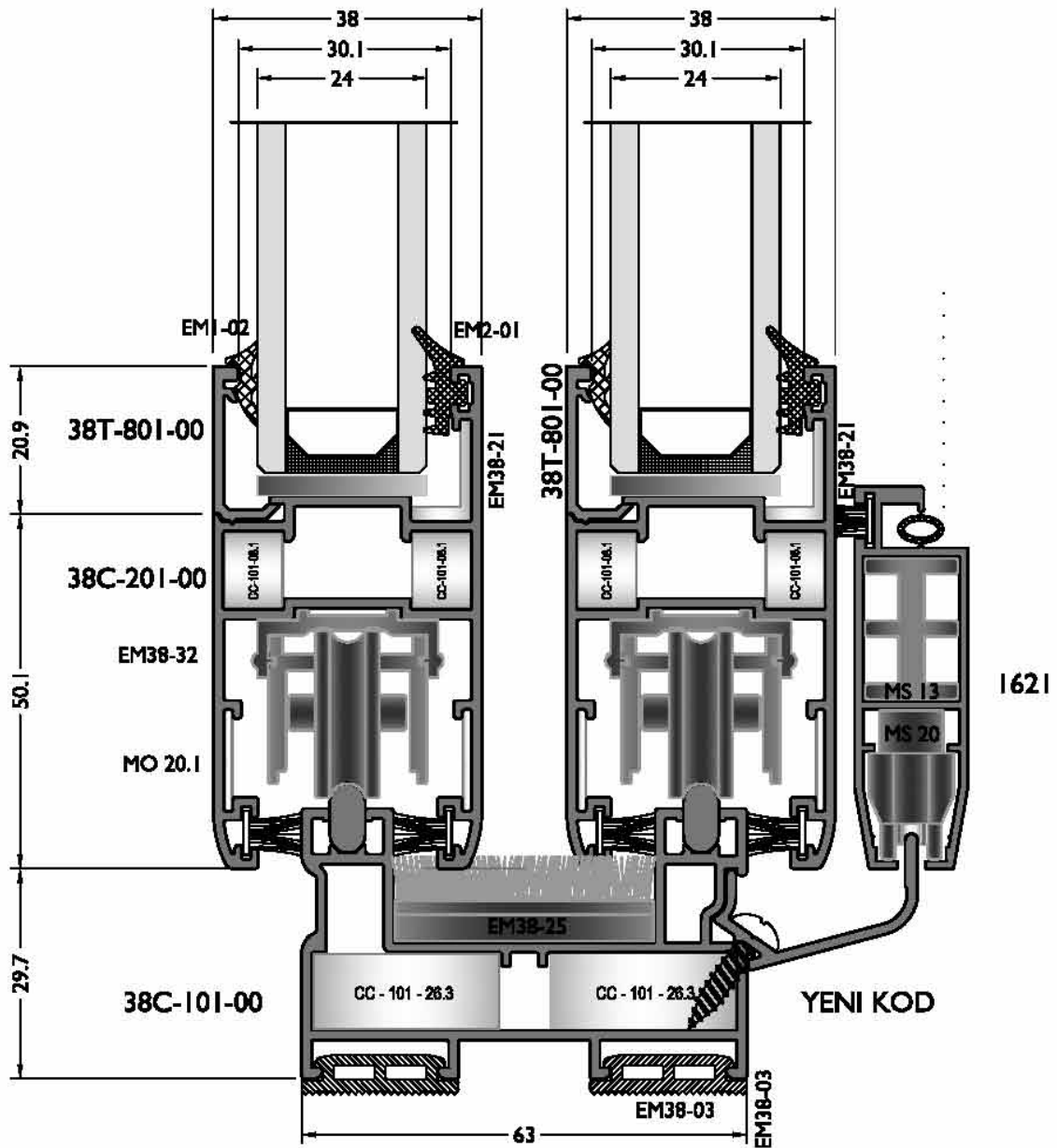
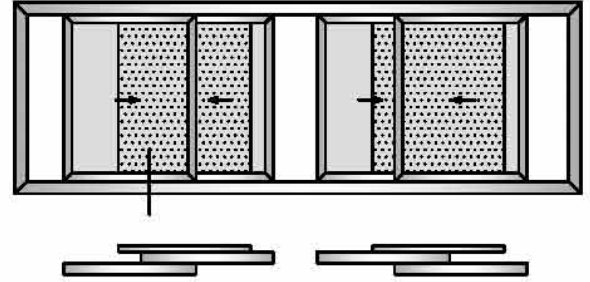
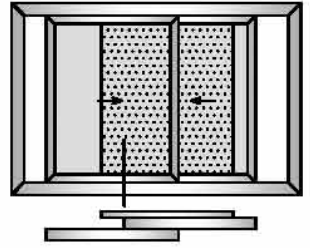

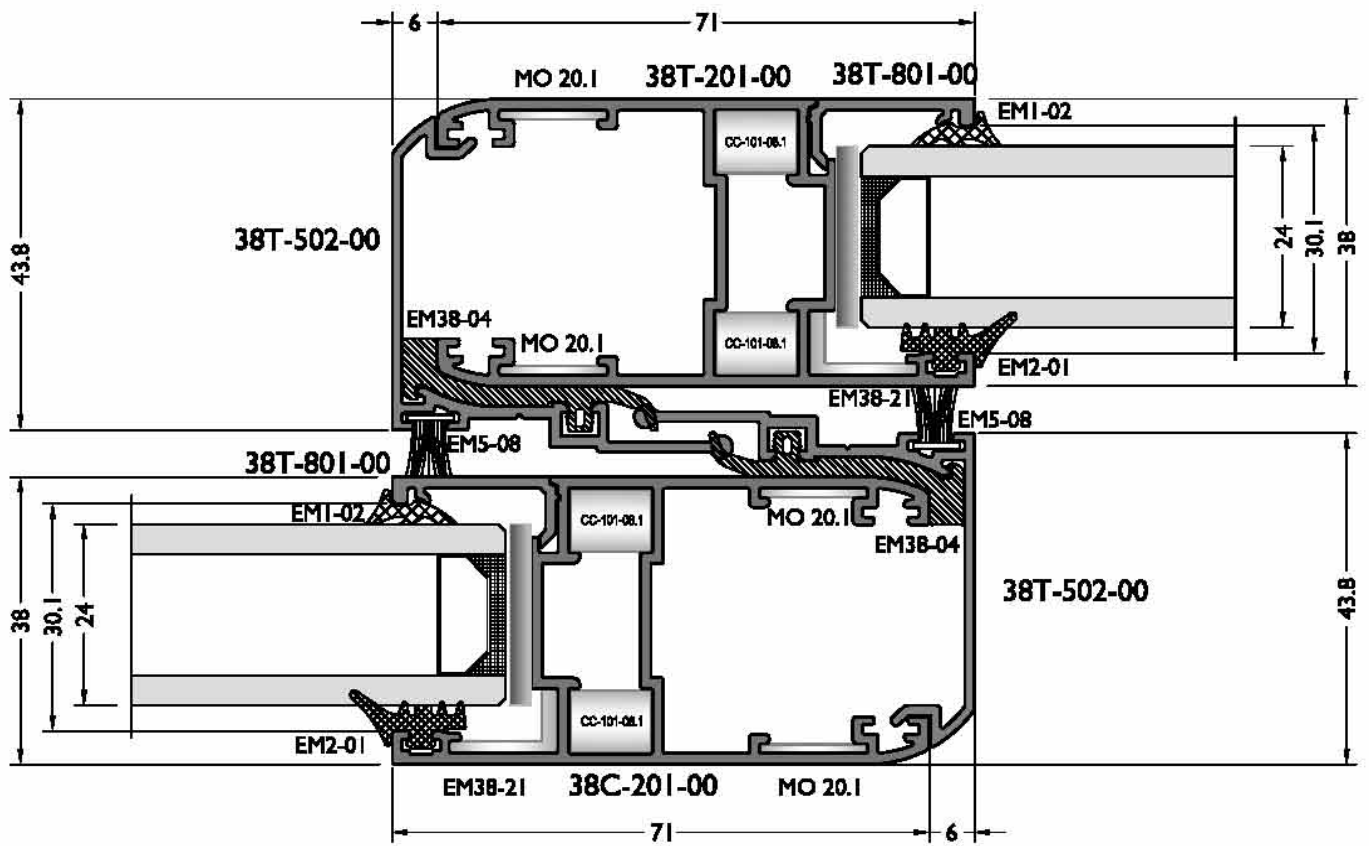
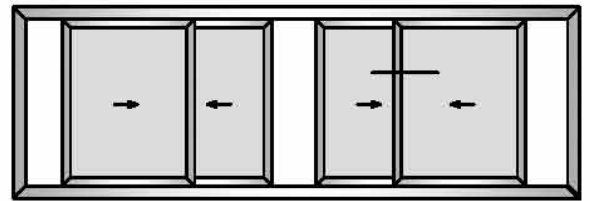
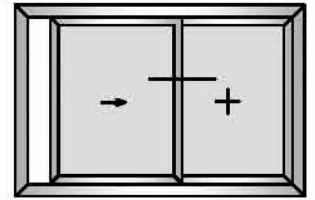
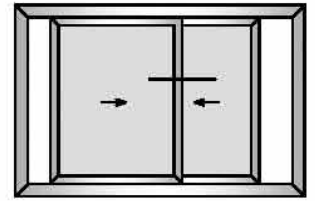

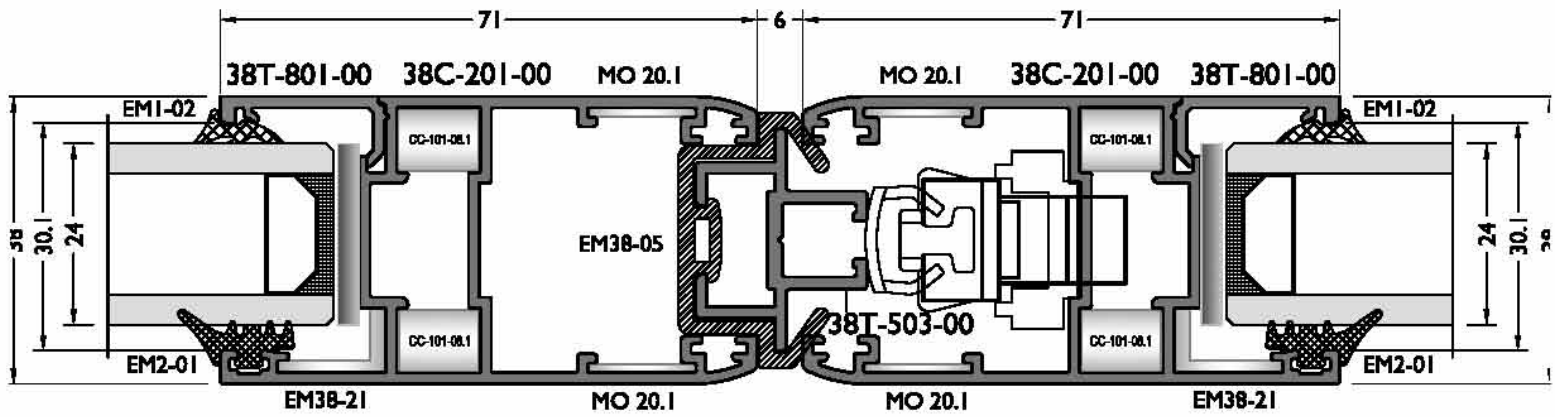
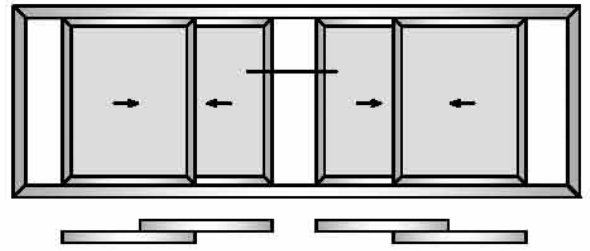

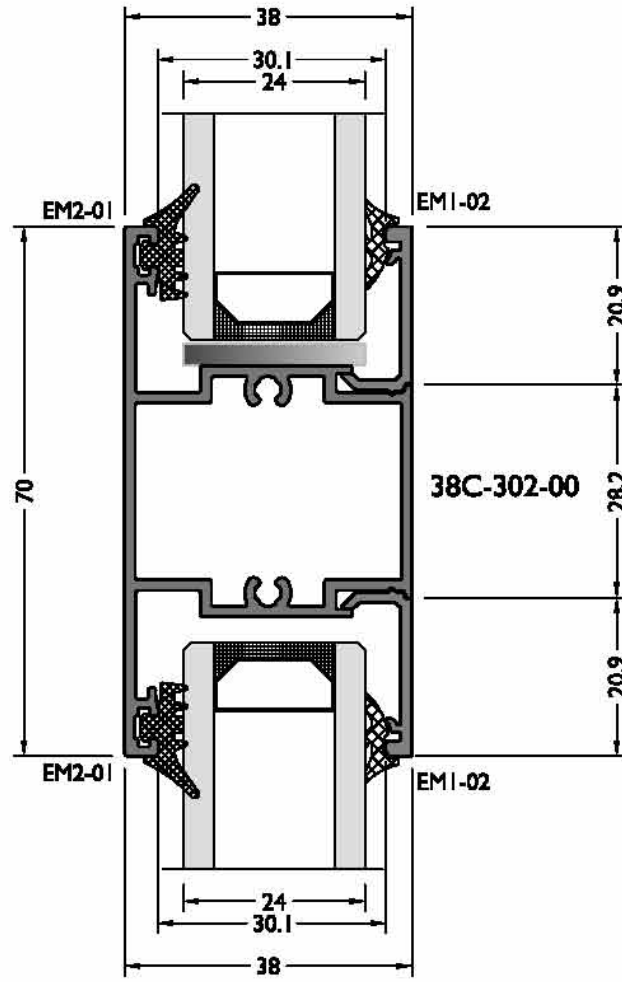
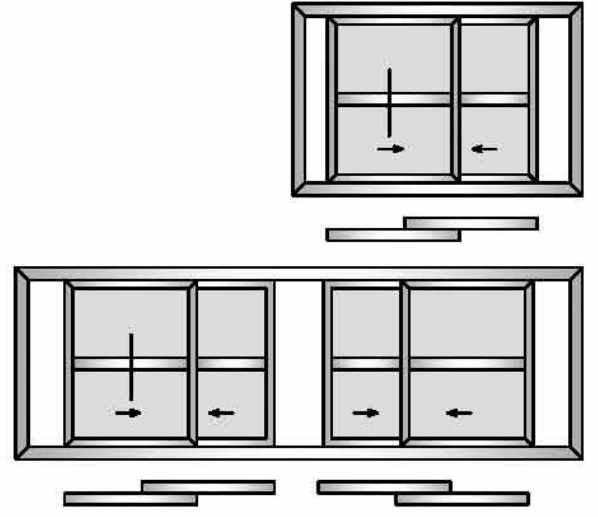

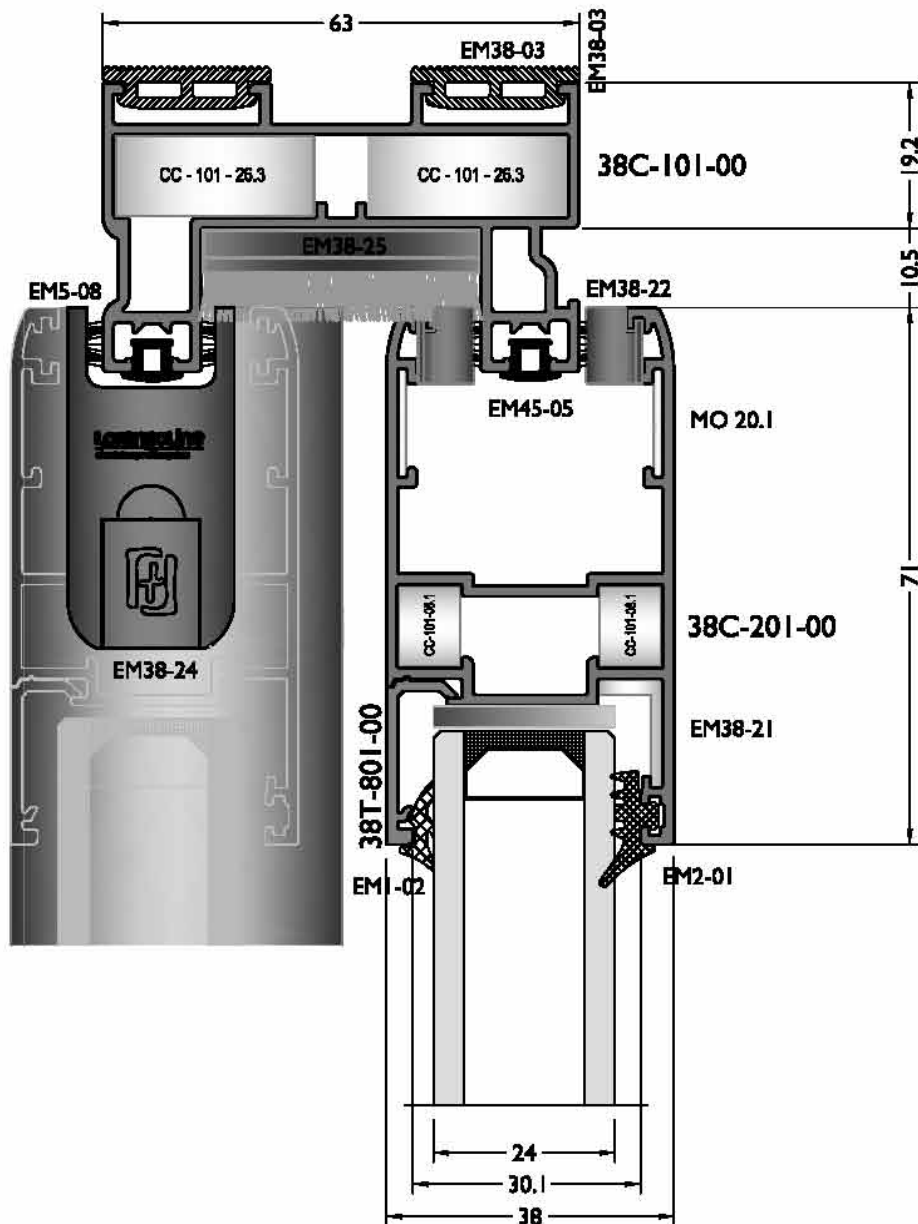
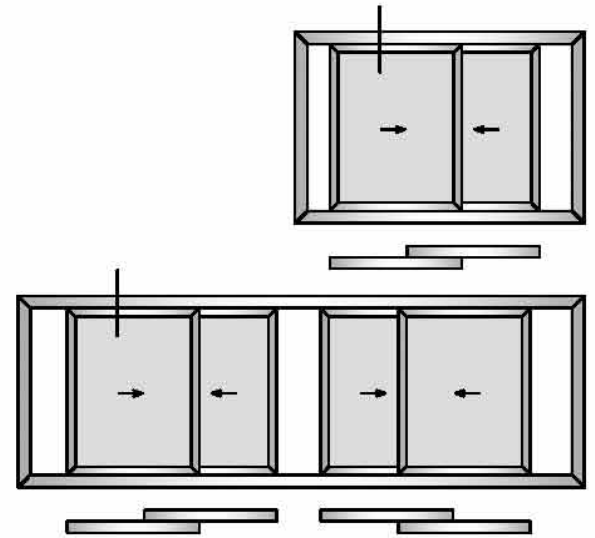

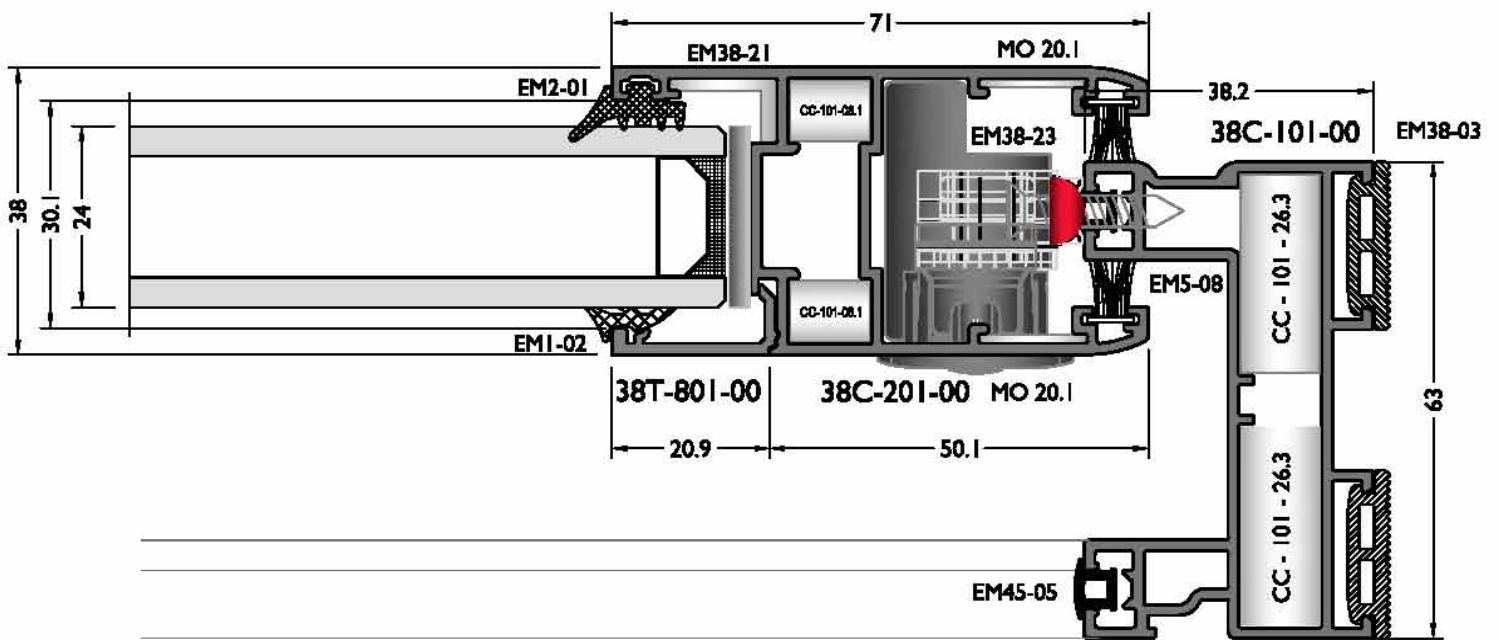
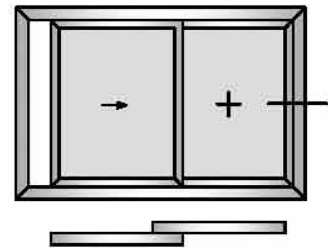
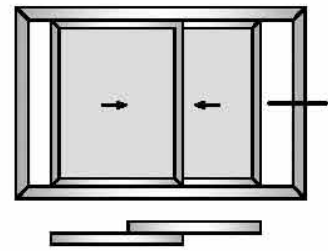

Cam Tablolari

Glazing tables

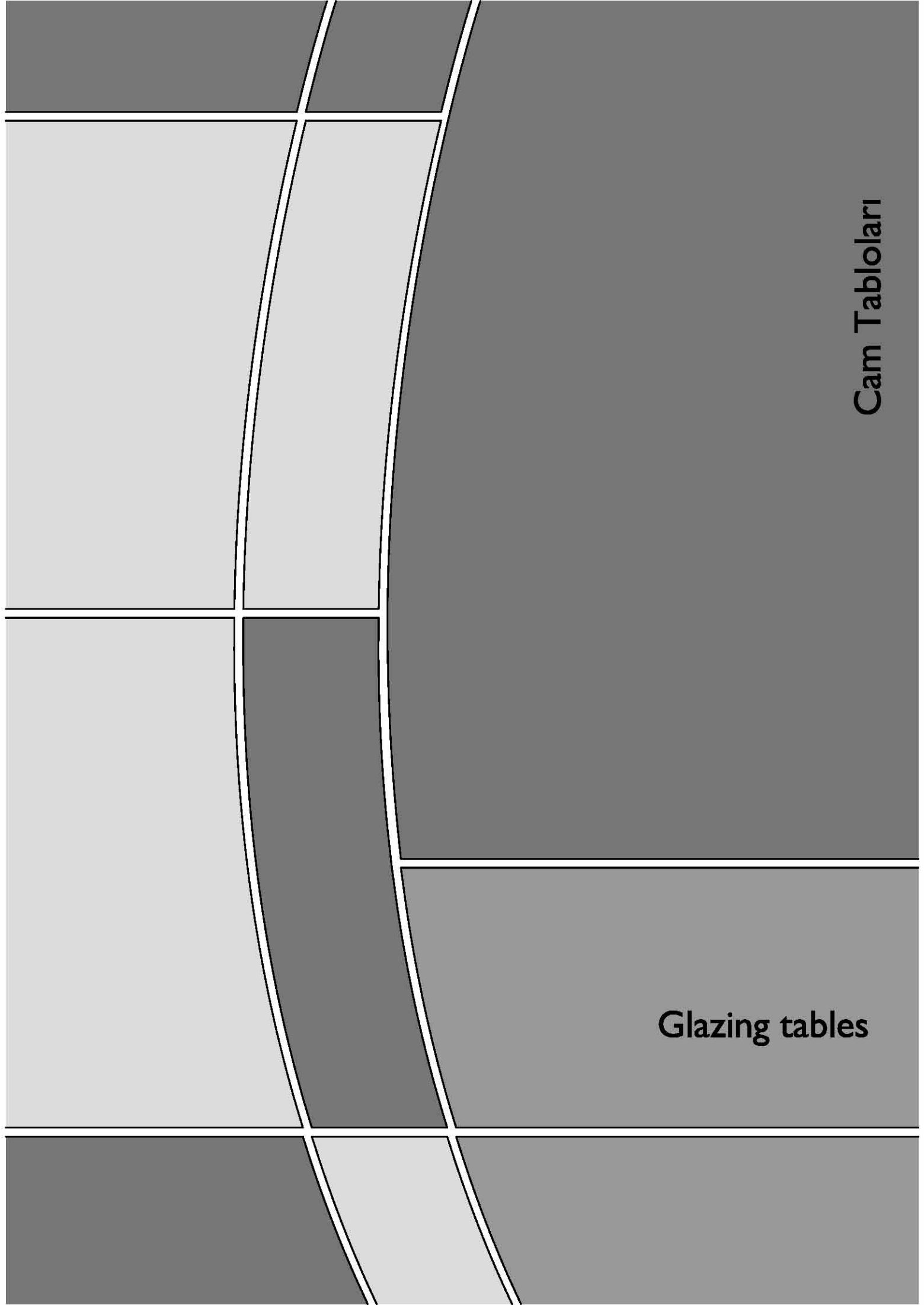





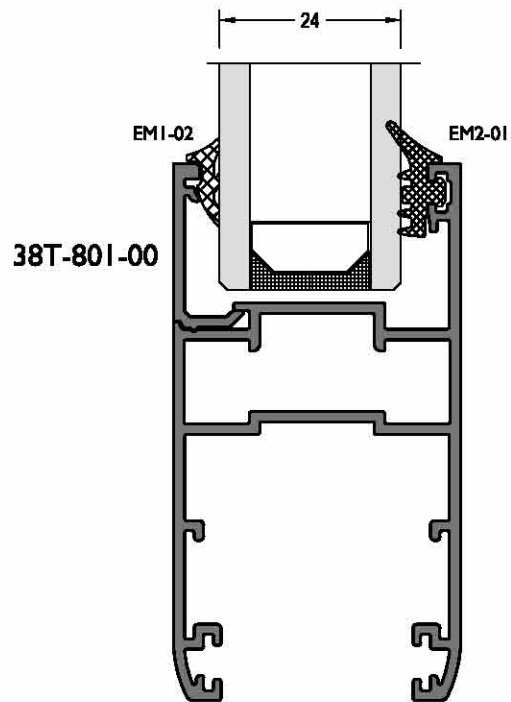
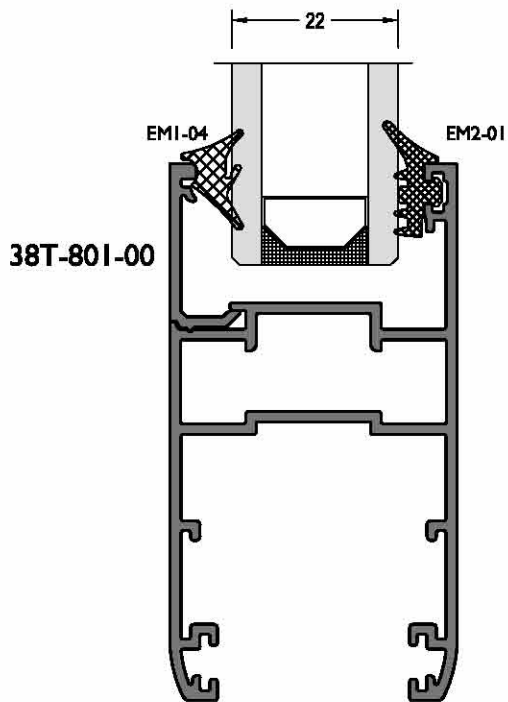
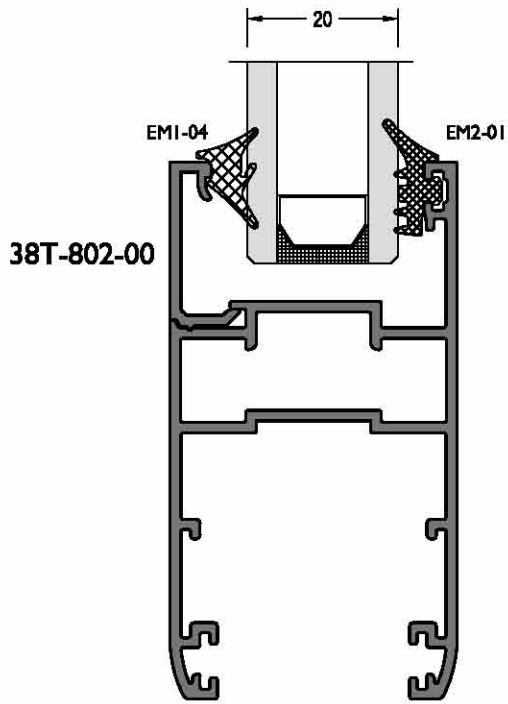









Glazing tables / cam tabloları

| GLAZING THICKNESS | GLAZING GASKET INSIDE | GLAZING GASKET OUTSIDE | GLAZING BEAD |
|-------------------|-----------------------|------------------------|--------------|
| 20 mm | EM1-04 | EM2-01 | 38T-802-00 |
| 22 mm | EM1-02 | EM2-01 | 38T-801-00 |
| 24 mm | EM1-04 | EM2-01 | 38T-801-00 |

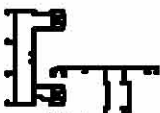
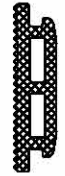

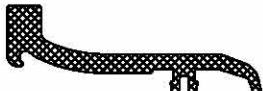

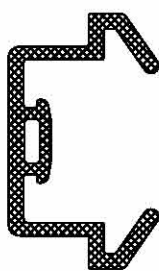





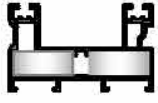

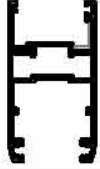

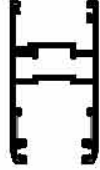



Aksesuarlar

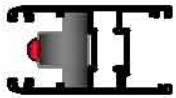

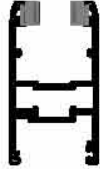
Accessories

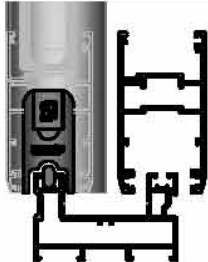

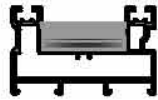
| CODE | DRAWING | APPLICATION | DESCRIPTION | THEORETICAL WEIGHT kg/m | IN ONE PACKAGE |
|---------|---|---|---------------------------------|-------------------------|----------------|
| EM1-02 |  |  | Glazing Gasket Inside (EPDM) | 0.050 | 300 m |
| EM1-04 |  |  | Glazing Gasket Inside (EPDM) | 0.070 | 215 m |
| EM2-01 |  |  | Glazing Gasket Outside (EPDM) | 0.055 | 270 m |
| EM5-08 |  |  | Brush | - | 225 m |
| EM45-05 |  |  | Frame Gasket (EPDM) | 0.030 | 500 m |
| EM38-03 |  |  | Frame Gasket (EPDM) | 0.110 | 136 m |
| EM38-04 |  |  | Clamping Gasket (EPDM) | 0.155 | 97 m |
| EM38-05 |  |  | Adaptor Gasket (EPDM) | 0.225 | 67 m |

accessories / aksesuarlar

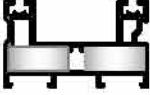
| ACCESSORY CODE | DRAWING | APPLICATION PROFILES | APPLICATION DETAIL |
|----------------|---|----------------------|---|
| LC-1127 |  | 38C-101-00 |  |
| EM38-21 |  | 38C-201-00 |  |
| MO 20.1 |  | 38C-201-00 |  |
| MS 13 |  | 1621 |  |

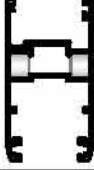
| ACCESSORY CODE | DRAWING | APPLICATION PROFILES | APPLICATION DETAIL |
|--|---|--------------------------------|---|
| EM38-23 |  | Stoper |  |
| EM38-22 |  | |  |
| EM38-24 |  | Cover Clip |  |
| EM38-25 |  | Weather strip |  |
| EM10-01 (White / Beyaz) |  | Drainage Cap Tahliye Kapagi |  |
| EM10-02 (Black / Siyah) | | | |
| EM10-03 (Brown / Kirengil) | | | |
| EM10-04 (Grey / Gri) | | | |
| EM10-05 (Light Coffee / Açik Kahve) | | | |

| PROFILE CODE | DRAWING | PACKAGE CODE | QUANTITY | CUTTING SIZE | APPLICATION PROFILES | APPLICATION DETAIL |
|--------------|---|--------------|-----------|--------------|----------------------|---|
| 09-101-00 |  | CC-101-26.3 | 75 pieces | 26.3 mm | 38C-101-00 |  |
| 09-101-00 |  | CC-101-08.1 | 90 pieces | 08.1 mm | 38C-201-00 |  |

| CODE | DESCRIPTION | PICTURE |
|-----------|--|---|
| EM38 - 91 | Embedding Handle Havuz Kol ve İletişim Ekipmanı |  |
| EM38 - 32 | Pulley With 2 Wheels Sürme İkil Rulman |  |
| MS 20 | Pulley |  |

Produced by 

KURTOĞLU BAKIR - KURŞUN SAN. A.Ş.

Hacıseremet Mevkii, Tem Çorlu Çıkışı Velimeşe 59880 Pk 323 Tekirdağ / TÜRKİYE

T: +90 282 684 70 00

F: +90 282 684 70 01

www.kurtogluas.com

kurtoglu@kurtogluas.com

 **Lorenzoline**[®]
aluminium profile system